

NOTES: UNLESS OTHERWISE SPECIFIED

1. MATERIAL: NICKEL STRIP 201, PER ASTM B 162 OR AMS 5553.
2. FINISH: SILVER PLATED PER AMS 2410.
3. THESE PARTS ARE ANNEALED. DIMENSIONS "A" AND "C" SHALL BE VERIFIED BY INSTALLING THE SEAL ON A STANDARD FITTING PER MS33514 OF APPROPRIATE SIZE. AN OUT-OF-ROUND CONDITION WHICH DOES NOT PREVENT SUCH INSTALLATION SHALL NOT BE A CAUSE FOR REJECTION UNLESS THE SEAL MATERIAL IS CREASED OR NICKED.
4. BREAK ALL SHARP EDGES AND REMOVE ALL BURRS.

REVISIONS

REV.	DESCRIPTION	DATE	APPROVED
G	As Released	7/15/1998	SECO

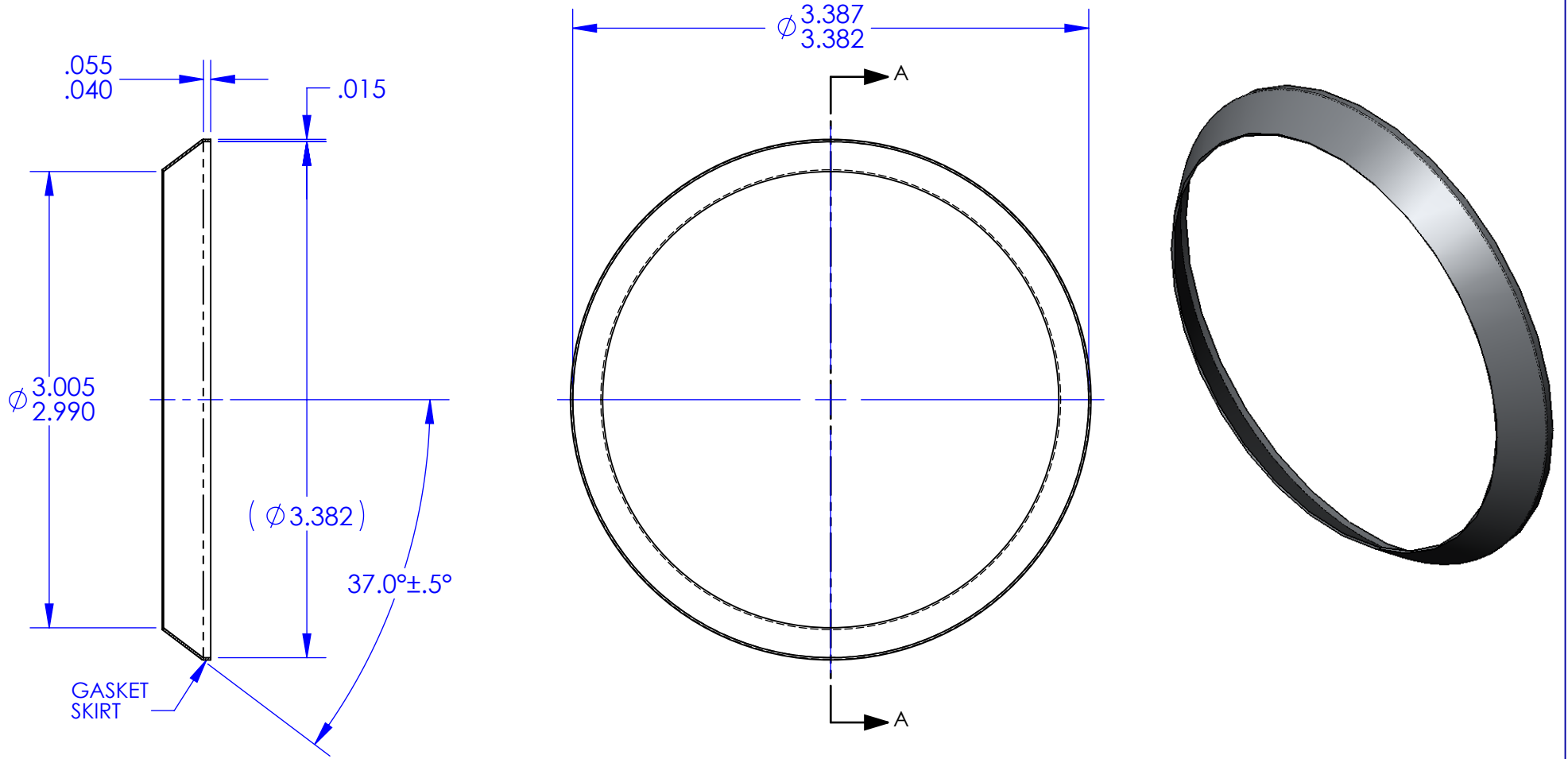

SECTION A-A

ECCN 9A991.d		DRAWING SIZE	SECO SEALS, INC. 1370 LOGAN AVE. UNIT K (714) 546-3478 PO BOX 1461 COSTA MESA, CA. 92626 www.secoseals.com	
MAT'L: See Note 1	FSCM: 4730	A	FILE NAME: SECO7NS48	REV. G
TREATMENT: Annealed after Forming	INCHES DIMENSIONS IN INCHES 3RD ANGLE PROJECTION		DESC.: Conical Seal for 3" Flared Tube Fitting, 37 Degree.	STANDARD: SECO 7
MAT'L SIZE: .015 Thk. Sheet			TITLE: SECO 7 Seal	DRAWN BY: Joe Littel
	DATE DRAWN: 4/21/2015		SCALE: 1:1	CHECKED BY: Jim Scott
			CAGE CODE: 33447	SHEET 1 of 1