

NOTES: UNLESS OTHERWISE SPECIFIED

1. MATERIAL: NICKEL STRIP 201, PER ASTM B 162 OR AMS 5553.
2. FINISH: TINPLATED PER MIL-T-10727, TYPE 1 OR AMS 2408-2.
3. THESE PARTS ARE ANNEALED. DIMENSIONS "A" AND "C" SHALL BE VERIFIED BY INSTALLING THE SEAL ON A STANDARD FITTING PER MS33514 OF APPROPRIATE SIZE. AN OUT-OF ROUND CONDITION WHICH DOES NOT PREVENT SUCH INSTALLATION SHALL NOT BE A CAUSE FOR REJECTION UNLESS THE SEAL MATERIAL IS CREASED OR NICKED.
4. BREAK ALL SHARP EDGES AND REMOVE ALL BURRS.

REVISIONS			
REV.	DESCRIPTION	DATE	APPROVED
G	As Released	7/15/1998	SECO

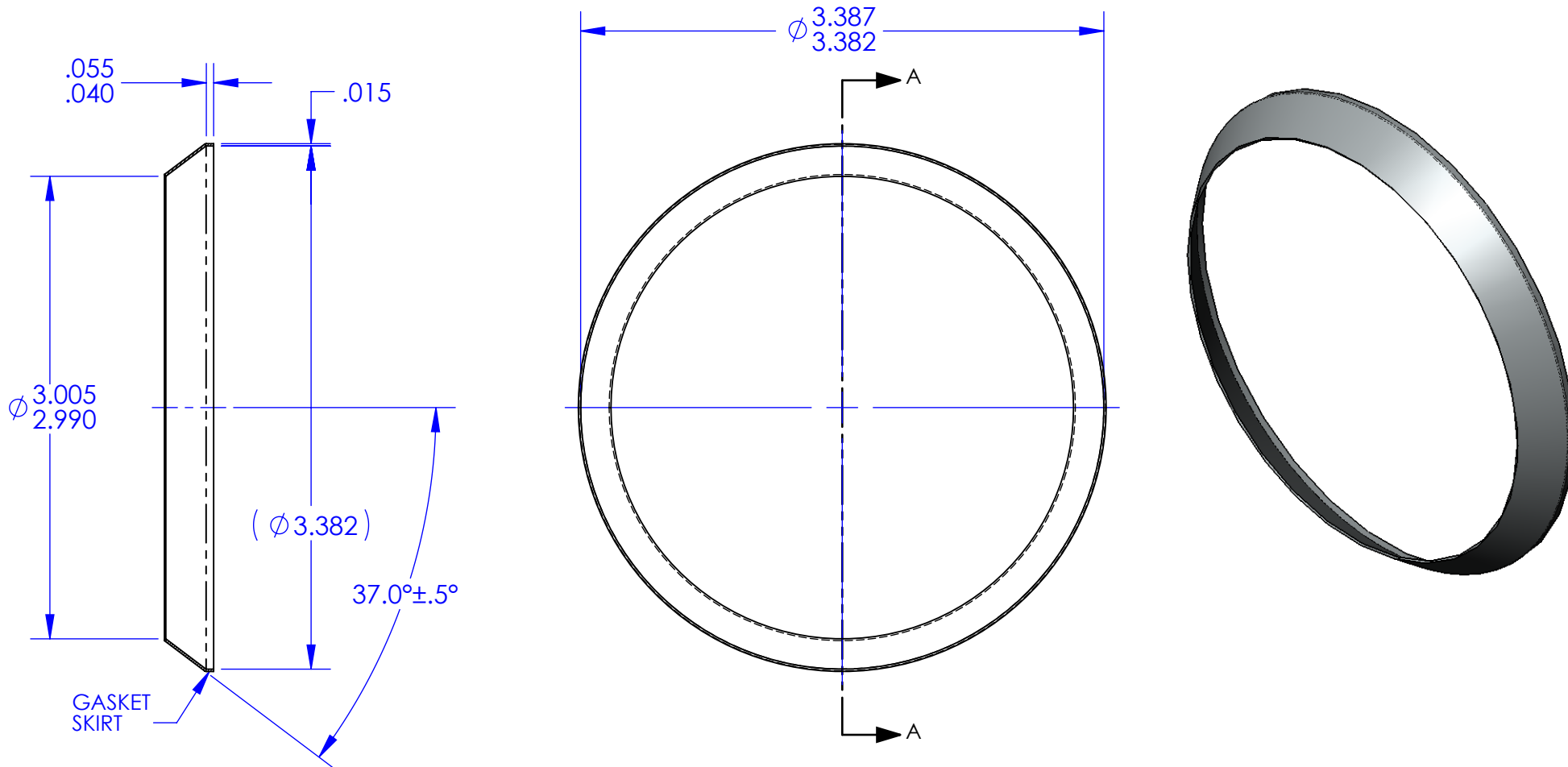

SECTION A-A

ECCN 9A991.d		DRAWING SIZE		SECO SEALS, INC.	1370 LOGAN AVE. UNIT K	(714) 546-3478
MAT'L:	FSCM:	A DIMENSIONS IN INCHES 3RD ANGLE PROJECTION		sales@secoseals.com	COSTA MESA, CA. 92626	www.secoseals.com
See Note 1	4730			FILE NAME:	SECO7NT48	REV.
TREATMENT:	INCHES DIMENSIONS IN INCHES 3RD ANGLE PROJECTION		DESC.:			STANDARD:
Annealed after Forming			Conical Seal for 3" Flared Tube Fitting, 37 Degree.			SECO 7
MAT'L SIZE:			TITLE:	DRAWN BY:	CAGE CODE:	
.015 Thk. Sheet			SECO 7 Seal	Joe Littel	33447	
		DATE DRAWN	SCALE	CHECKED BY:	SHEET	
		4/21/2015	1:1	Jim Scott	1 of 1	